

PediPlates®

SURGICAL TECHNIQUE

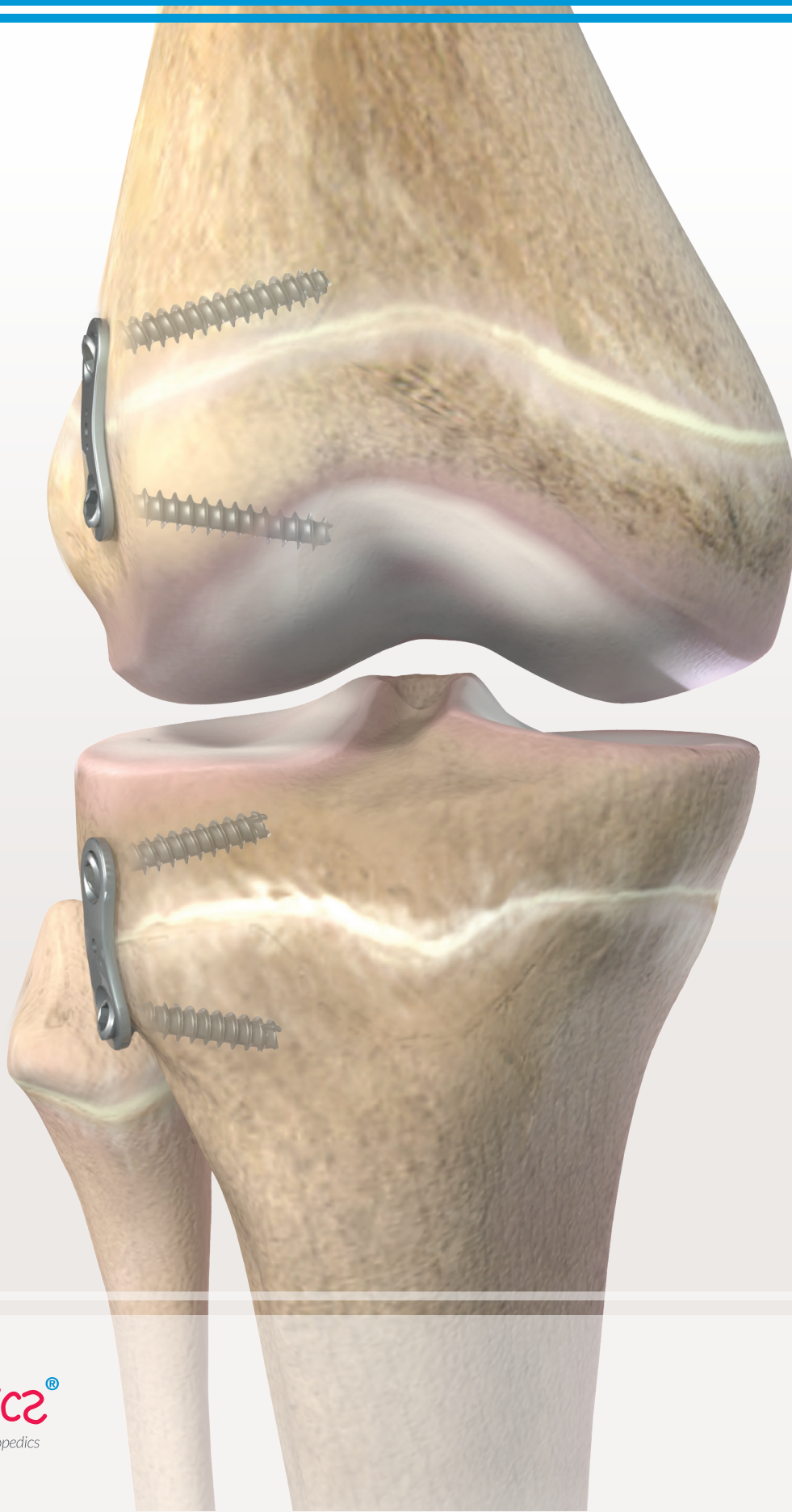

System Overview

System Overview 3

System Features 3

Surgical Technique

Lateral Distal Femoral Physeal Tethering

Surgical Approach 4

Guide Wire Insertion 4

Plate Placement 4

Distal Femoral Epiphyseal Guide Wire Insertion 5

Distal Femoral Metaphyseal Guide Wire Insertion 6

Plate Positioning Confirmation 6

Epiphyseal Screw Insertion 7

Metaphyseal Screw Insertion 8

Final Tightening 9

Closure 9

Technical Tips

Technical Tips 10

Product Information

O-Plate and I-Plate Implants 11

O-Plate and I-Plate Instrumentation 12

PediPlate Delta Implants 13

PediPlate Delta Instrumentation 13

PediPlate Titanium 14

SYSTEM OVERVIEW

Physeal tethering techniques that do not disrupt the integrity of the physis have grown in popularity recently. These techniques utilize simple plate and screw constructs which span the peripheral part of the physis, resulting in a restraint of the growth that would normally occur there. The implant inhibits growth in the area where the plate and screws are applied. By tethering only one side of the physis, growth is inhibited in that area and not inhibited in other regions of the physis. If both sides of physis are tethered, longitudinal growth may temporarily be retarded (for up to 2 years). This growth tethering is simple, minimally invasive, temporary and reversible. Techniques that take advantage of open growth plates are unique and allow for gradual correction with significantly less morbidity than other forms of growth arrest or inhibition such as stapling or transphyseal screws.

SYSTEM FEATURES

- Stainless steel plates and screws provide excellent strength, resistance to breakage, as well as ease of removal.
- Implants also available in Titanium, for a more comprehensive system offering.
- Multiple plate sizes and configurations offer greater options and more flexibility.
- All screws are self-tapping for easy insertion.
- Utilizes 4.5mm stainless steel cannulated and non-cannulated screws with multiple screw length options.
- Low-profile plates.
- Low-profile screws in Stainless Steel and Titanium for use in areas where soft-tissue irritation is a consideration.
- The O-Plate addresses the majority of patients needing simple two-hole physeal tethering.
- The Delta Plate addresses situations where more flexibility of screw placement is needed by offering maximum diversion of screw placement through the plate.
- The I-Plate provides additional fixation options utilizing four, rather than two screws.

SURGICAL TECHNIQUE

Lateral Distal Femoral Physeal Tethering

1

Surgical Approach

Identify and locate the distal femoral physis with a metal object and fluoroscopy. Mark the skin and make a small incision longitudinally. Gently dissect down to the peri-chondral ring, being careful not to damage it (Figure 1).

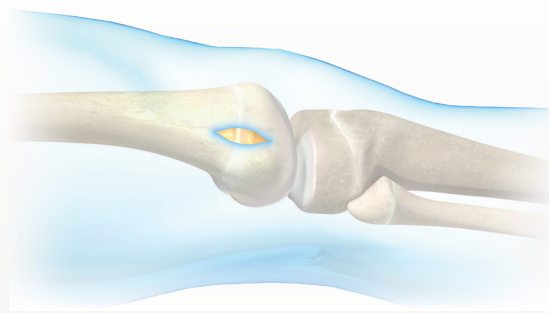

FIGURE 1: Surgical incision

2

Place Guide Wire in Physis

Using fluoroscopic confirmation, place the 1.6mm guide wire into the physis ensuring that the guide wire is in the center of the distal femoral condyles, anterior to posterior. Insert the guide wire gently into the physis, about 1cm in depth (Figure 2).

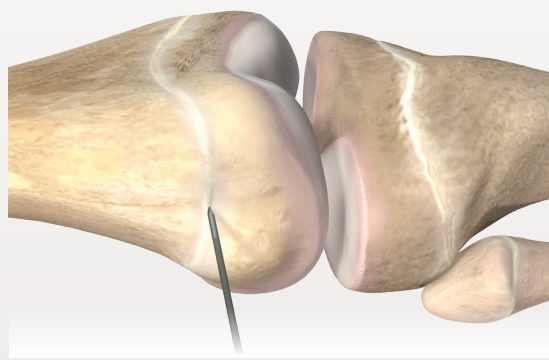

FIGURE 2: Guide wire insertion into physis

- 1 *Note: Upon placement of guide wires throughout the procedure, ensure there is no damage to the wire. Damage may result in complications with the patient or interactions with other mating devices.*

3

Plate Placement

Select an appropriate sized plate and slide it over the guide wire down to the bone (Figure 3).

Caution: Avoid selecting inappropriate sized plate that would allow placement of a screw into the physis or joint space.

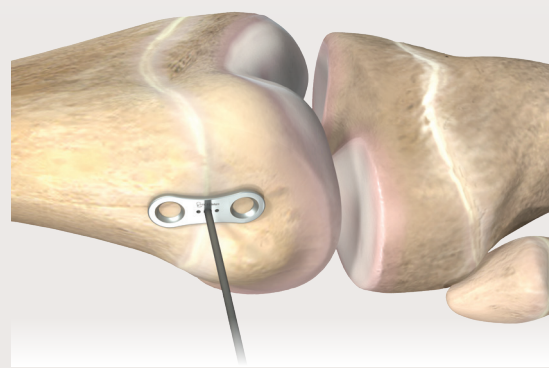

FIGURE 3: Plate placement

4

Insert 1.6mm Guide Wire into the Distal Femoral Epiphyseal Bone

Using the self-centering drill guide for the 1.6mm guide wire (Figure 4a and 4b), insert the wire under power into the distal femoral epiphysis making sure that the wire is contained within the epiphysis. If the wire is close to the physis or through the physis, remove it and reposition it. Using fluoroscopy, confirm placement of the 1.6mm guide wire prior to proceeding.

- 1 *Note: Ensure the double drill guide is centered within the epiphyseal hole especially when using a double drill guide without the centering hole (01-1010-010).*
- 2 *Note: Prior to drilling, ensure power tool settings are in the forward position and no obstructions are in the path of intended drilling.*

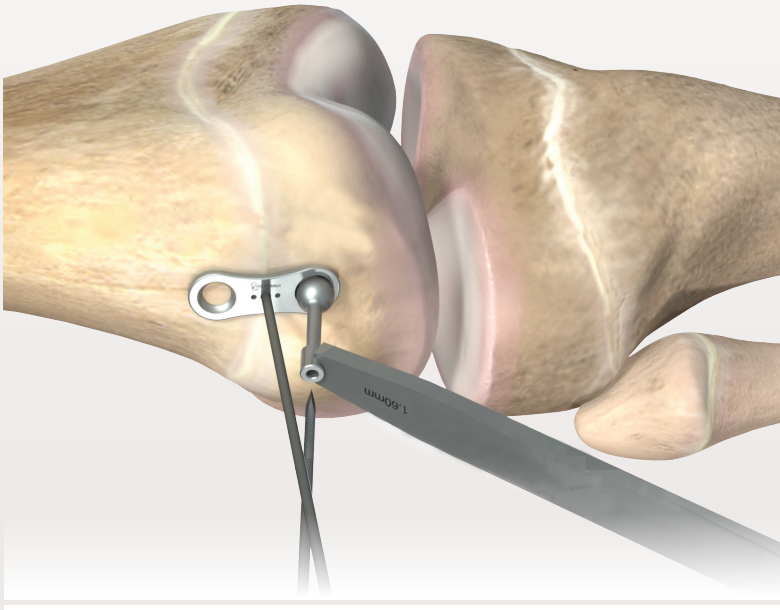

FIGURE 4a: Guide wire insertion into distal femoral epiphysis

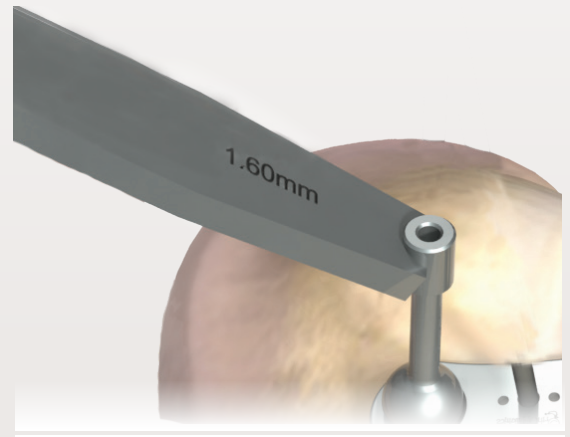

FIGURE 4b: 1.6mm side of drill guide must be used for guide wire insertion

5

Insert 1.6mm Guide Wire into the Distal Femoral Metaphyseal Bone

Using the drill guide for the 1.6mm guide wire, insert the wire under power into the distal femoral metaphysis making sure to angle away from the physis (Figure 5). Confirm placement of the 1.6mm guide wire with fluoroscopy in the distal femoral metaphysis.

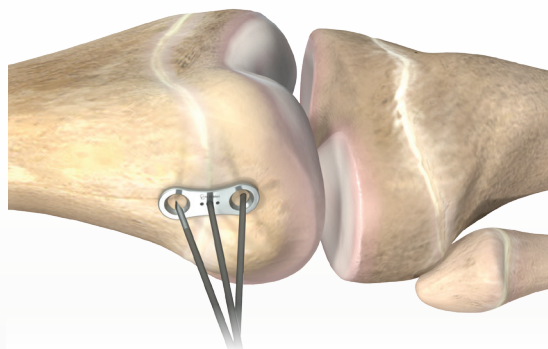

FIGURE 5: Guide wire insertion into distal femoral metaphysis

6

Confirm Plate Positioning

Using fluoroscopy, confirm position of plate and guide wires by taking an A/P image and a lateral image (Figure 6). The ideal plate placement is in the middle of the femoral condyle anterior to posterior and in line longitudinally with the shaft of the femur. It is more important for the plate to be positioned in the center of the distal femoral condyle, than it is to be in line longitudinally. If the plate is positioned too far anterior or too far posterior, recurvatum or procurvatum may be created.

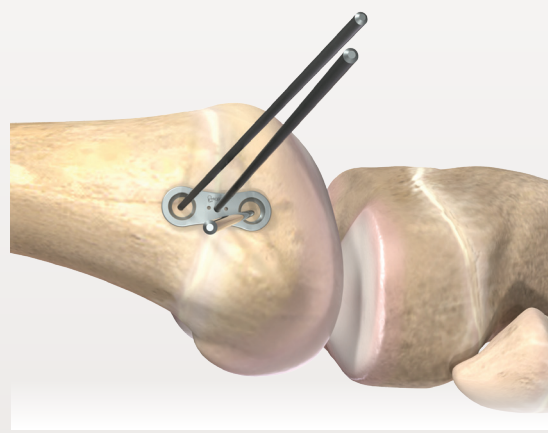

FIGURE 6: Plate positioning

7

Measure and Drill for Epiphyseal Screw

Using the direct measuring device, identify the appropriate screw length (Figure 7a). Drill over the 1.6mm guide wire using the 3.2mm cannulated drill bit to pre-drill for insertion of the screw (Figure 7b). It is not necessary to drill past the cortex. The epiphyseal screw should be about one-third of the distance across the segment of the bone.

If using the double drill guide with stop (01-1010-0210), advance the 3.2mm cannulated drill bit until it will no longer advance. This will ensure you have only drilled the near cortex.

- 1 *Note: If the 3.2mm cannulated drill bit does not advance easily over the 1.6mm guide wire, remove the drill bit and check the integrity of the guide wire. If bent or damaged, the 3.2mm cannulated drill bit may cause the guide wire to be inadvertently advanced. If using a drill guide, check to be sure that the drill guide is not damaged.*

8

Insert Epiphyseal Screw

Select the appropriate size of screw from the caddy. Size can be confirmed using the scale on the screw caddy. To obtain accurate measurement, be sure to push the screw forward on the scale so that the screw head makes contact with the edge of the caddy.

Insert screw over guide wire into epiphysis ensuring screw is not tightened completely at this stage of insertion (Figure 8). Confirm placement of the screw using fluoroscopy.

Caution: If using a non cannulated screw, be sure to remove the guide wire before inserting the screw. Verify the trajectory of the screw by using fluoroscopy. Pre-drilling the cortex is recommended using the 3.2mm drill bit.

Warning: Never mix metals.

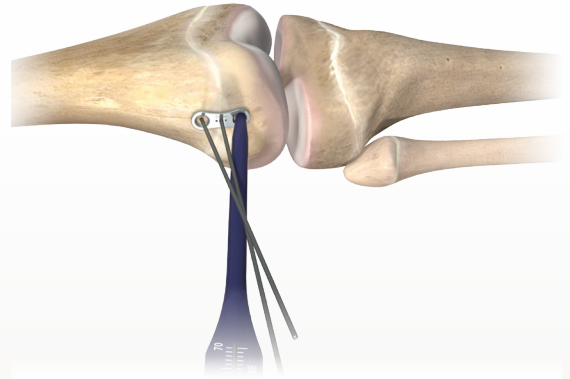

FIGURE 7a: Read the direct measuring device calibration markings from the end of the guide wire

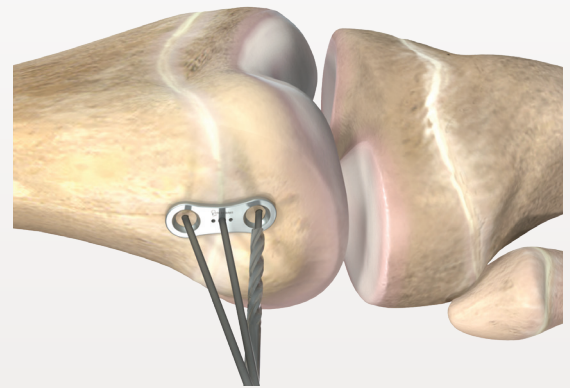

FIGURE 7b: Drill over guide wire for the epiphyseal screw

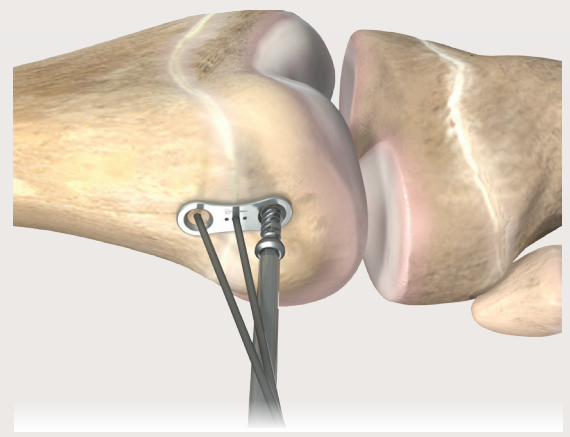

FIGURE 8: Epiphyseal screw insertion

9

Measure and Drill for Metaphyseal Screw

Using the direct measuring device, identify the appropriate screw length. Drill over the 1.6mm guide wire using the 3.2mm cannulated drill bit to pre-drill for insertion of the screw. It is not necessary to drill past the cortex. The metaphyseal screw should be about one-third of the distance across the segment of the bone.

As stated earlier, if using double drill guide with stop (01-1010-0210), advance the 3.2mm cannulated drill bit until it will no longer advance. This will ensure that you have only drilled the near cortex.

10

Insert Metaphyseal Screw

Select the appropriate size of screw from the caddy. Size can be confirmed using the scale on the screw caddy.

Insert screw over guide wire into metaphysis ensuring screw is not tightened completely at this stage of insertion (Figure 9). Confirm placement of the screw using fluoroscopy.

Caution: If using non cannulated screws, be sure to remove the guide wire before inserting the screw. Verify the trajectory of the screw by using fluoroscopy. Pre-drilling the cortex is recommended using the 3.2mm drill bit.

Warning: *Never mix metals.*

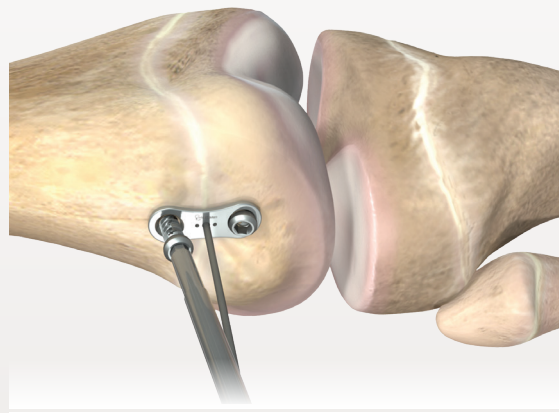

FIGURE 9: Metaphyseal screw insertion

11

Final Tightening

Prior to final tightening, remove the physeal guide wire. Complete final tightening by alternatively tightening between metaphyseal and epiphyseal screws (Figure 10).

Caution: Not removing the physeal guide wire before final tightening can result in the pin fracturing and difficult removal of the pin.

- 1 *Note: If needed, use fluoroscopy to confirm plate is flush with the bone. The screws should be fully seated and not enter the physis.*

12

Closure

Close the wound.

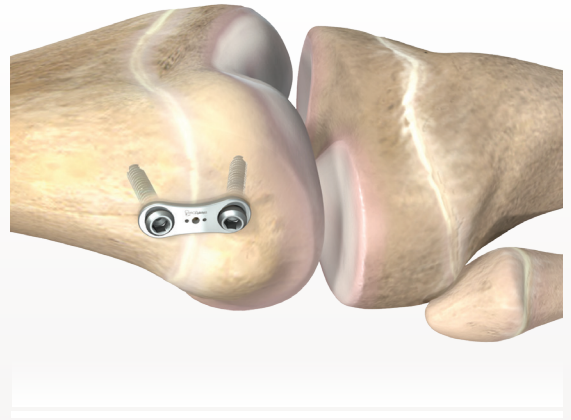
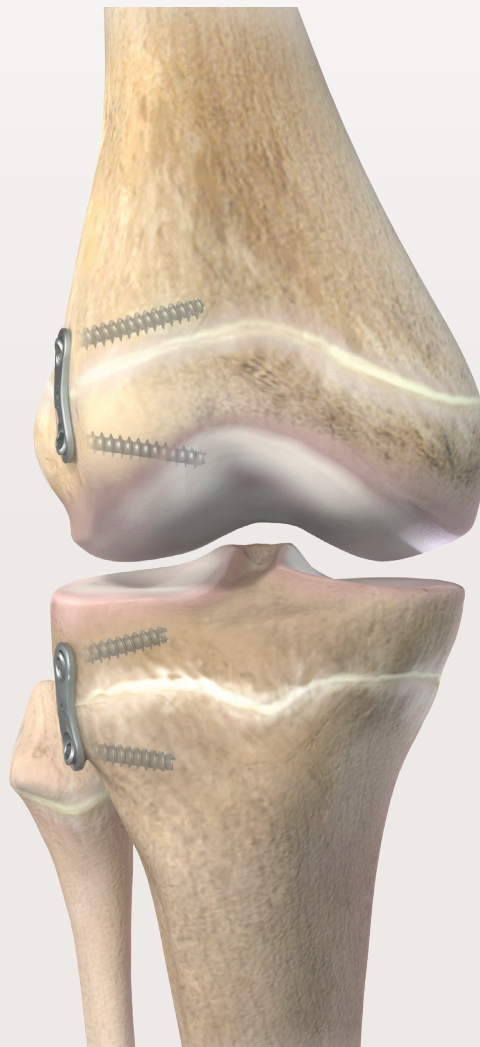

FIGURE 10: Final tightening of metaphyseal and epiphyseal screws

TECHNICAL TIPS

- Make sure all screws are tightened sequentially and that the plate is adjacent to the bone. It is sometimes necessary to gently bend the plate in order to get it to fit onto the bone. This is often the case in the proximal tibia. If the plate is not adherent to the bone, additional stress may be exerted onto the screws potentially leading to screw breakage.
- It is not necessary to drill past the cortex for placement of the screws. Simply drill the outer cortex into the epiphysis/metaphysis with the 3.2mm drill bit. All the screws are self-tapping and are easily inserted into epiphyseal/metaphyseal bone.
- Use caution when using the Low Profile PediPlate Screws with PediPlate Delta. Delta allows for maximum divergence of screws within the plate and it is possible for the Low Profile PediPlate Screws to disengage from PediPlate Delta at maximum divergence.
- Timing of removal of implants is critical. If the implants are left in too long, overcorrection may occur and additional stress to the implants may occur. Overcorrection can lead to development of a bony deformity. Additional stress to the implants may compromise implant integrity making removal difficult. Be sure to routinely follow patients throughout growth modulation for signs of implant stress and fatigue.



O-PLATE AND I-PLATE

Implants

Item Number	Qty	Description
4.5mm Cannulated Screws		
00-1015-316	8	4.5mm x 16mm Cannulated Screw
00-1015-320	8	4.5mm x 20mm Cannulated Screw
00-1015-324	8	4.5mm x 24mm Cannulated Screw
00-1015-328	8	4.5mm x 28mm Cannulated Screw
00-1015-332	8	4.5mm x 32mm Cannulated Screw
00-1015-336	8	4.5mm x 36mm Cannulated Screw

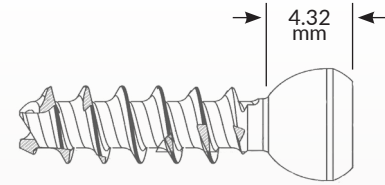

4.5mm Low Profile Screws		
00-1015-616	8	LP 4.5mm x 16mm Cannulated Screw
00-1015-620	8	LP 4.5mm x 20mm Cannulated Screw
00-1015-624	8	LP 4.5mm x 24mm Cannulated Screw
00-1015-628	8	LP 4.5mm x 28mm Cannulated Screw
00-1015-632	8	LP 4.5mm x 32mm Cannulated Screw

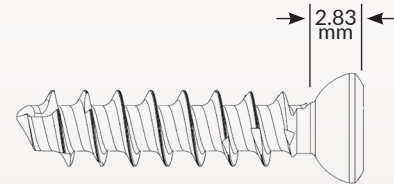

4.5mm Solid Screws		
00-1015-516	8	4.5mm x 16mm Solid Screw
00-1015-520	8	4.5mm x 20mm Solid Screw
00-1015-524	8	4.5mm x 24mm Solid Screw
00-1015-528	8	4.5mm x 28mm Solid Screw
00-1015-532	8	4.5mm x 32mm Solid Screw
00-1015-536	8	4.5mm x 36mm Solid Screw

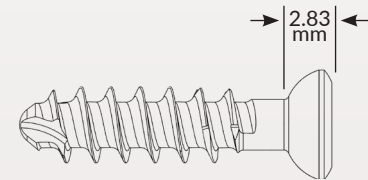

O-Plates		
00-1012-212	4	O-Plate 12mm - Center Hole
00-1012-216	4	O-Plate 16mm - Center Hole
00-1012-220	4	O-Plate 20mm - Center Hole
00-1012-224	4	O-Plate 24mm - Center Hole

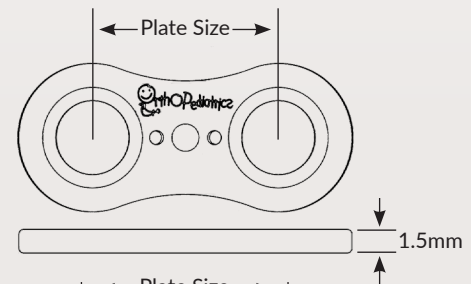

I-Plates		
00-1015-416	2	I-Plate 16mm - Center Hole
00-1015-422	2	I-Plate 22mm - Center Hole
00-1015-432	2	I-Plate 32mm - Center Hole

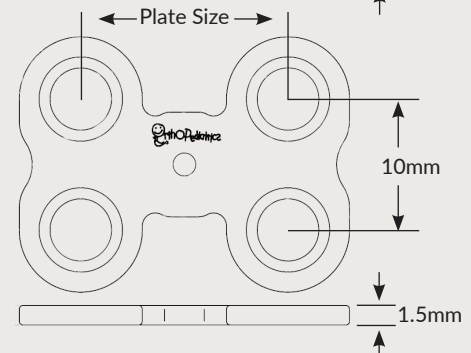

I-PLATE AND O-PLATE

Instrumentation

Item Number	Qty	Description
Drill and Drill Guides		
01-1010-009	2	AO 3.2mm Cannulated Drill
01-1010-010	1	Double Drill Guide
09-1010-010	1	Self-Centering Drill Guide
Guide Wires		
01-1010-007	10	1.6mm Guide Wire, Threaded
01-1050-0039	10	1.6mm Guide Wire, Smooth (optional)
Screwdrivers		
01-1010-006	1	3.5mm Cannulated Hex Screwdriver, AO fitting
01-1010-014	1	3.5mm Hex Screwdriver, AO fitting
Bending Irons		
01-1010-002	1	Bending Iron, Right
01-1010-013	1	Bending Iron, Left
Miscellaneous		
01-1030-009	1	Direct Measuring Device
01-1010-012	1	Depth Gauge
01-1030-001	1	Mini In-line Ratchet w/ small AO push/pull coupling
01-1010-001	1	Mini T-Handle
01-1010-003	1	1.7mm Cleaning Brush
01-1010-004	1	Cleaning Stylet
01-1030-007	1	Self-Holding Screw Forceps
Case and Tray		
01-1010-603	1	Case Bottom
01-1010-604	1	Case Tray
01-1010-905	1	Case Lid
01-1010-906	1	Case Screw Caddy
01-1010-951	1	PediPlate Solid Screw Caddy
01-1010-952	1	PediPlate Solid Screw Caddy Lid

PEDIPLATE DELTA

Item Number	Qty	Description
Delta Screws		
00-1015-0716	8	4.5mm x 16mm Cannulated Screw, Delta
00-1015-0720	8	4.5mm x 20mm Cannulated Screw, Delta
00-1015-0724	8	4.5mm x 24mm Cannulated Screw, Delta
00-1015-0728	8	4.5mm x 28mm Cannulated Screw, Delta
00-1015-0732	8	4.5mm x 32mm Cannulated Screw, Delta
00-1015-0736	8	4.5mm x 36mm Cannulated Screw, Delta

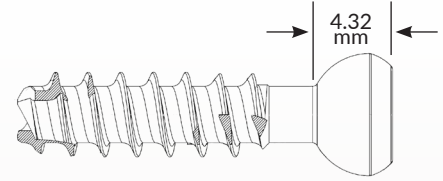

Delta Plates		
00-1012-0312	4	PediPlate Delta 12mm
00-1012-0316	4	PediPlate Delta 16mm
00-1012-0320	4	PediPlate Delta 20mm
00-1012-0324	4	PediPlate Delta 24mm

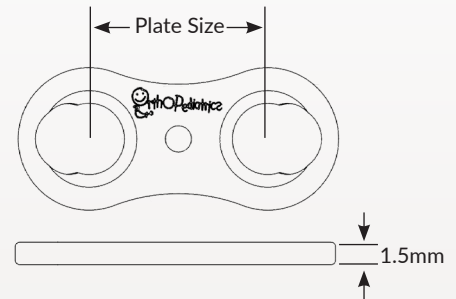

Delta-Specific Instrumentation

01-1010-0209	1	3.2mm Cannulated Drill, Delta
01-1010-0210	1	Double Drill Guide, Delta

Delta Case and Tray

01-1010-0610	1	PediPlate Delta Base
01-1010-0612	1	PediPlate Delta Case Lid
01-1010-0611	1	PediPlate Delta Tray
01-1010-0615	1	PediPlate Delta Tray Lid
01-1010-0613	1	PediPlate Delta Screw Caddy
01-1010-0614	1	PediPlate Delta Screw Caddy Lid

PEDIPLATE TITANIUM

Item Number	Qty	Description
Screws		
00-1015-8016	8	4.5mm Cannulated Screw, Ti, 16mm
00-1015-8020	8	4.5mm Cannulated Screw, Ti 20mm
00-1015-8024	8	4.5mm Cannulated Screw, Ti, 24mm
00-1015-8028	8	4.5mm Cannulated Screw, Ti, 28mm
00-1015-8032	8	4.5mm Cannulated Screw, Ti, 32mm
00-1015-8036	8	4.5mm Cannulated Screw, Ti, 36mm
00-1015-8116	8	4.5mm Solid Screw, Ti, 16mm
00-1015-8120	8	4.5mm Solid Screw, Ti, 20mm
00-1015-8124	8	4.5mm Solid Screw, Ti, 24mm
00-1015-8128	8	4.5mm Solid Screw, Ti, 28mm
00-1015-8132	8	4.5mm Solid Screw, Ti, 32mm
00-1015-8136	8	4.5mm Solid Screw, Ti, 36mm
Plates		
00-1015-8212	4	O-Plate, Ti 12mm
00-1015-8216	4	O-Plate, Ti 16mm
00-1015-8220	4	O-Plate, Ti 20mm
00-1015-8224	4	O-Plate, Ti 24mm
00-1015-8416	2	I-Plate, Ti 16mm
00-1015-8422	2	I-Plate, Ti 22mm
00-1015-8432	2	I-Plate, Ti 32mm
Case and Tray		
01-1012-0001	1	Titanium PediPlates Tray
01-1012-0002	1	Titanium PediPlates Lid
01-1012-0003	1	Titanium PediPlates Cannulated Screw Caddy, LP
01-1012-0004	1	Titanium PediPlates Solid Screw Caddy, LP
01-1012-0005	1	Titanium PediPlates Cannulated Screw Caddy Lid, LP
01-1012-0006	1	Titanium PediPlates Solid Screw Caddy Lid, LP
01-1012-0011	1	Titanium PediPlates Plate Caddy
01-1012-0012	1	Titanium PediPlates Plate Caddy Lid

WARNING: Never mix metals.

CAUTION: Federal law restricts this device to sale by or the order of a Physician.

CAUTION: Devices are supplied Non-Sterile. Clean and sterilize before use according to instructions.

CAUTION: Implants components are single-use. Do not reuse.

CAUTION: The device is not approved for screw attachment or fixation to the posterior elements (pedicles) of the cervical, thoracic or lumbar spine.

CAUTION: Only those instruments and implants contained within this system are recommended for use with this technique. Other instruments or implants used in combination or in place of those contained within this system is not recommended.

NOTE: This technique has been provided by one of our medical advisors only as guidance and it is not intended to limit the methods used by trained and experienced surgeons.

Instructions For Use (IFU), cleaning instructions, and surgical techniques may be obtained by calling OrthoPediatrics® Customer Service at 574-268-6379. Read and understand indications, warnings, and adverse effects explained in IFU's prior to use.

This document is intended exclusively for experts in the field, i.e. physicians in particular, and expressly not for the information of laypersons.

The information on the products and/or procedures contained in this document is of general nature and does not represent medical advice or recommendations. Since this information does not constitute any diagnostic or therapeutic statement with regard to any individual medical case, individual examination and advising of the respective patient are absolutely necessary and are not replaced by this document in whole or in part.

The information contained in this document was gathered and compiled by medical experts and qualified OrthoPediatrics employees to the best of their knowledge. The greatest care was taken to ensure the accuracy and ease of the understanding of the information used and presented.

OrthoPediatrics does not assume any liability, however, for the timeliness, accuracy, completeness or quality of the information and excludes any liability for tangible or intangible losses that may be caused by the use of this information.

OrthoPediatrics, ArmorLink, BandLoc Duo, PediFlex, PediFoot, PediFrag, PediGraft, PediLoc, PediNail, PediPlates, PLEO, QuickPack, RESPONSE, Scwire, ShieldLoc, TorqLoc, PediPedal and the OP and Pedi logos are trademarks of OrthoPediatrics Corp.

OrthoPediatrics is a registered trademark in Brazil, S.Korea, and the U.S.A. PediLoc and PediPlates are registered trademarks in Chile and the U.S.A. The OP logo is a registered trademark in Colombia, European Union, Japan, and the U.S.A. The Pedi logo is a registered trademark in Argentina, Australia, Brazil, Chile, Colombia, European Union, Israel, Mexico, New Zealand, S.Korea, Taiwan, Turkey, and the U.S.A. ArmorLink is a registered trademark in the U.S.A. Scwire is a registered trademark in the U.S.A. ShieldLoc is a registered trademark in the U.S.A. TorqLoc is a registered trademark in the U.S.A.